

UCrypt[®] Q2Q



Patent Pending

QAM to QAM
(front view)

QAM to QAM with Pro:Idiom[®] Encryption *

Features

- The UCrypt[®] QAM to QAM product offering allows MSOs to decrypt select programs from their digital tier, re-encrypt them with Pro:Idiom[®] or leave them in-the-clear and retransmit them via QAM 64 or 256
- Ideal for providing a full complement of reclaimed analog channels in digital SD as well as providing additional HD channels to any hospitality or bulk MDU accounts affected by analog tier migration initiatives
- Support for H.264 streams
- Includes configurable line card style EPG channel
- Allows for PSIP VCT insertion for customizing virtual channel lineup on property TVs
- Features a true field-upgradeable design to easily add channel capacity on an as-required basis as well as easily replaceable redundant power supply modules
- HTTPS-based management interface allows operators to monitor, manage and configure the product remotely



UC2 Q2Q (front view)

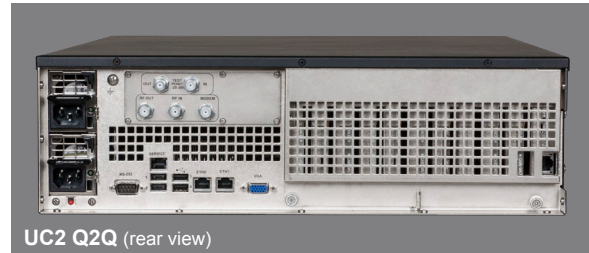

UC2 Q2Q (rear view)

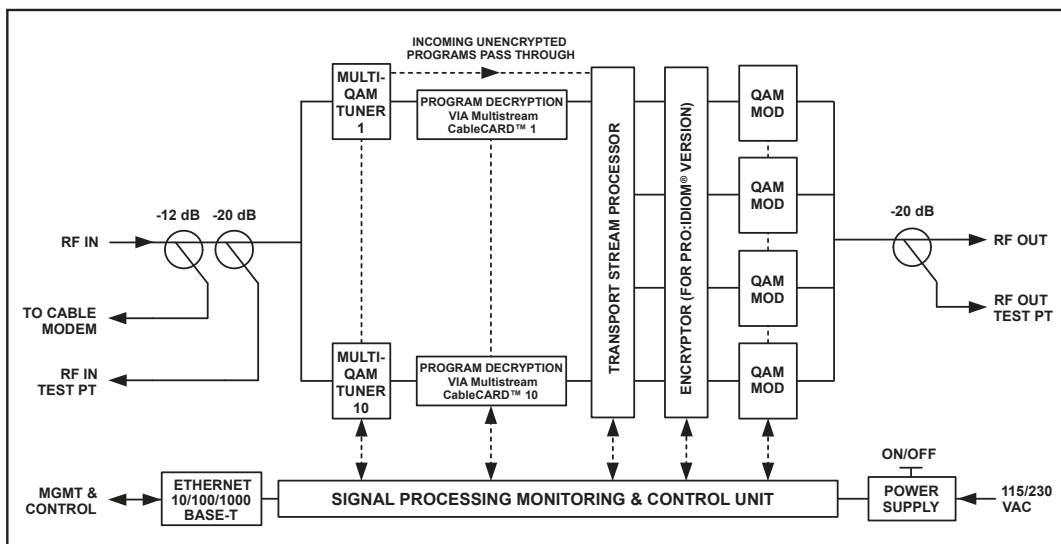

Functional Schematic

Specifications

QAM to QAM

INPUT	
RF QAM	Up to 60 64 QAM and 256 QAM Tuners ⁽¹⁾
RF QPSK	Complies with ANSI/SCTE 55-1&2 2.048 Mbps and 1.544/3.088 Mbps, ANSI/SCTE 40
CONNECTOR	F Connector; Chassis Rear
FREQUENCY RANGE	54 MHz - 1 GHz in 1 kHz Steps, Supporting STD, IRC, HRC
ADJACENT QAM CHANNEL REQUIREMENT	None; All Tuners Individually Agile
RF INPUT	+5 to +10 dBmV per Digital Carrier
RF INPUT TEST	-20 dB Relative to Input; F Connector, Chassis Rear
TS PROCESSING	
PASSED CONTENT	Decrypt up to 60 Programs ⁽¹⁾ Using up to 10 Multistream CableCARD™ Devices Remaining Unencrypted Content can be Transferred to the Device Output
CABLECARD DECRYPTION	Supports Motorola, Scientific Atlanta/Cisco, and NDS
MULTIPLEXING CAPACITY	Flexible Creation of up to 32 SPTS and/or MPTS ⁽¹⁾ (38.8 Mbps max each) with PAT/PMT Generation per TS
ENCRYPTION	Pro:Idiom Encrypted Multiplex or Unencrypted Multiplex
ENCRYPTION CAPACITY	Up to 32 SPTS and/or MPTS Multiplexes ⁽¹⁾ (38.8 Mbps max each)
SUPPORTED VIDEO FORMATS	MPEG-2 MP@HL, MPEG-4 pt10 AVC/H.264 HP@L4
SUPPORTED VIDEO RESOLUTIONS	Up to 720p and 1080i
SUPPORTED AUDIO FORMATS	Dolby® Digital (AC-3), MPEG-1 L1/2
CLOSED CAPTION (CC)	Pass through original EIA 608/708 Closed Captioning
OUTPUT	
RF	Up to 32 64 QAM and 256 QAM Channels ⁽¹⁾ in Groups of Four Adjacent QAMs
FREQUENCY RANGE	54 MHz - 1 GHz in 1 kHz Steps, Supporting STD, IRC, HRC
LEVEL	38 dBmV +/- 2 dB per Digital Carrier
MER	> 40 dB
CONNECTOR	F Connector; Chassis Rear
RF OUTPUT TEST	-20 dB Relative to Output; F Connector, Chassis Rear
DEVICE MANAGEMENT	
MANAGEMENT INTERFACE	Local or Remote Management via Integrated Secure Web Server
MANAGEMENT INTERFACE PORT	10/100/1000BASE-T, Static IP or DHCP, RJ45, Chassis Rear
SECONDARY CRAFT PORT	10/100/1000BASE-T, Static IP, RJ45, Chassis Rear
MANAGEMENT SECURITY	3 Password Protected Tiered User Accounts
MASS DEPLOYMENT & BACKUP	Importable/Exportable Device Configuration Files
REMOTE MONITORING	Integrated SNMP Agent and MIB
REMOTE MANAGEMENT SUPPORT	F Connector Provided for Optional MSO Supplied Cable Modem Installation for Remote Management
ALARMS	Email Notification, SNMP Traps
EAS	
MODES	Support for ANSI/SCTE 18 Compliant and Non-compliant Devices
PHYSICAL & ENVIRONMENTAL	
FORM FACTOR	3RU, 19" Rack Mount
DIMENSIONS	5.25"H x 19.0"W x 23.96"D (13.34H x 48.26W x 60.86D cm)
WEIGHT (Max)	50.2 lbs (22.8 kg)
INPUT POWER	4.0 Amps @ 115 VAC, 2.0 Amps @ 230 VAC
POWER REDUNDANCY	Fully Redundant 650W Power Supply Modules, Hot-swappable
ELECTRICAL APPROVAL	Approved to UL 60950-1, 2nd Edition (File E325862)
POWER CONTROL	Software Power Control
OPERATING TEMPERATURE	0°C to +40°C ⁽²⁾ (+32°F to +104°F)
HUMIDITY	0-95% Non-condensing

NOTES:

(1) Depends upon ordered hardware options.

(2) For details on exceeding +30°C, please refer to the UCrypt Environment & Temperature Considerations Info Sheet (#ANW1066).

Dolby is a registered trademark of Dolby Laboratories. Manufactured under license from Dolby Laboratories.

Ordering Information

Part Number	Description
UC 2.0 Q2Q with CLEAR Output	
UCT12/8	UC2 Q2Q 12 Tuner/Decrypt 8 QAM Clear Out
UCT12/16	UC2 Q2Q 12 Tuner/Decrypt 16 QAM Clear Out
UCT24/16	UC2 Q2Q 24 Tuner/Decrypt 16 QAM Clear Out
UCT24/24	UC2 Q2Q 24 Tuner/Decrypt 24 QAM Clear Out
UCT48/24	UC2 Q2Q 48 Tuner/Decrypt 24 QAM Clear Out
UCT48/32	UC2 Q2Q 48 Tuner/Decrypt 32 QAM Clear Out
UCT60/8	UC2 Q2Q 60 Tuner/Decrypt 8 QAM Clear Out
UCT60/24	UC2 Q2Q 60 Tuner/Decrypt 24 QAM Clear Out
UCT60/32	UC2 Q2Q 60 Tuner/Decrypt 32 QAM Clear Out
UC 2.0 Q2Q with PRO:IDIOM Output	
UCT12/8P	UC2 Q2Q 12 Tuner/Decrypt 8 QAM Pro:Idiom Out
UCT12/16P	UC2 Q2Q 12 Tuner/Decrypt 16 QAM Pro:Idiom Out
UCT24/16P	UC2 Q2Q 24 Tuner/Decrypt 16 QAM Pro:Idiom Out
UCT24/24P	UC2 Q2Q 24 Tuner/Decrypt 24 QAM Pro:Idiom Out
UCT48/24P	UC2 Q2Q 48 Tuner/Decrypt 24 QAM Pro:Idiom Out
UCT48/32P	UC2 Q2Q 48 Tuner/Decrypt 32 QAM Pro:Idiom Out
UCT60/8P	UC2 Q2Q 60 Tuner/Decrypt 8 QAM Pro:Idiom Out
UCT60/24P	UC2 Q2Q 60 Tuner/Decrypt 24 QAM Pro:Idiom Out
UCT60/32P	UC2 Q2Q 60 Tuner/Decrypt 32 QAM Pro:Idiom Out
Power Supply Modules	
UCTPSMOD-AC3	UCrypt AC Power Supply Module 3
UCTPSMOD-DC1	UCrypt DC Power Supply Module 1

* Any use of the UCrypt product, directly or indirectly, for the decryption and unauthorized reproduction of content that constitutes or may constitute copyright infringement or otherwise infringes on the proprietary rights of any third party is expressly prohibited. No user of UCrypt shall use UCrypt for any purpose or in any manner which, directly or indirectly, violates the law, violates the proprietary rights of any other party, or aids in any unlawful act or undertaking including, without limitation, laws governing data privacy, international data transmission, and export of technology or data. Any multiple systems operator or other similar party ("MSO") will use the UCrypt product in strict compliance with all applicable laws and in compliance with any agreement in effect between the MSO and a content provider. In no event shall ATX Networks Corp. or any of its affiliates be liable to an MSO, any end user of the UCrypt product, or any other third party, for any claims arising out of or related to any use or misuse of the UCrypt product in contravention of this disclaimer. It is the express obligation of an MSO to convey this disclaimer to any other end user of the UCrypt product.

UCrypt devices support most desktop web browsers for viewing and editing. Our support is focused on the most recent versions of the browsers. Chrome™ and Firefox® supported on PC, Mac®, and Linux®; Microsoft® Edge and Internet Explorer® 11 (Windows® 8+) are only supported for PC. We recommend using the latest browser version available to your operating system.

MDU Solutions® and UCrypt® are registered trademarks of ATX in the United States and/or other countries. Products or features contained herein may be covered by one or more U.S. or foreign patents. Pro:Idiom®, Dolby®, CableCARD™, Chrome™, Firefox®, PC, Mac®, Linux®, Microsoft® Edge, Internet Explorer®, Windows® and other non-ATX product and company names mentioned in this data sheet are the property of their respective companies.

© 2019 by ATX Networks Corp. and its affiliates (collectively "ATX Networks Corp."). All rights reserved. This material may not be published, broadcast, rewritten, or redistributed. Information in this document is subject to change without notice.
Rev. 11/19 (ANW0935)



ATX Networks

Tel: 289.204.7800 | Toll-Free: 866.YOUR.ATX | support@atx.com