

# GigaXtend

## Extended Spectrum Taps



**XST-28-20**  
(front view)

The GigaXtend™ family of Taps and Line Passives injects immediate cost and performance benefits into existing HFC networks, as well as positions cable operators to seamlessly extend the bandwidth capabilities of their HFC networks to 2GHz and beyond.

GigaXtend technology is essential to MSOs looking to minimize costs associated with N+0 deployments, eliminate amplifier re-spacing or reduce the need for additional amplifiers during bandwidth upgrades, or simply want to extend the spectrum of the HFC network beyond 2GHz. A further benefit of GigaXtend is future support for RF performance beyond 3GHz through a simple faceplate upgrade. GigaXtend is compatible with any delivery technology, including Frequency Division Duplexed (FDD), Full Duplex DOCSIS (FDX), as well as Extended Spectrum DOCSIS (ESD).

## Features

- Industry-leading loss and bandwidth extends reach and power of any outside plant, especially fiber deep Node+0 deployments and may upgrade plant bandwidth without amplifier respacing
- Reversed faceplate options of all tap SKUs, supporting change of RF direction in plant
- Base supports future faceplate upgrade of > 3GHz
- >15A continuous AC power passing, with uninterrupted AC/RF bypass
- Optional: Up to 2A drop power on single F tap port (powering small cell, 5G, etc). Refer to ANW1538 for drop power option.
- Plug in conditioner, supporting Cable Sim/EQ or Return Attenuation
- 90-degree, screw-less 5/8-24 entry port, increasing reliability and installation speed
- Environmentally hardened, powder-coated, chip resistant aluminum housing for extreme outdoor conditions
- Waterproof and RFI gaskets in faceplate. New material with any faceplate upgrade.

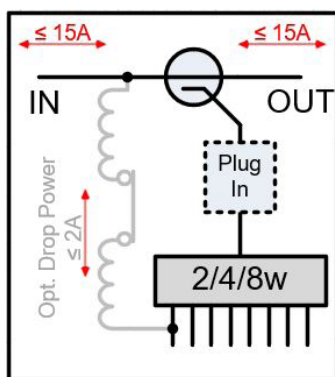

Functional Schematic

# Specifications

## GigaXtend 8 Port Taps

ATX PART NUMBER		XST-28-14T		XST-28-17		XST-28-20		XST-28-23		XST-28-26		XST-28-29	
NOMINAL TAP VALUE, dB		14		17		20		23		26		29	
SPECIFICATION	MHz	TYP	MAX	TYP	MAX	TYP	MAX	TYP	MAX	TYP	MAX	TYP	MAX
Insertion Loss IN-OUT dB	5	-	-	3.3	3.8	2.0	2.4	1.4	2.0	1.0	1.2	0.9	1.1
	10	-	-	3.3	3.8	2.0	2.2	1.4	1.8	1.0	1.1	0.9	1.1
	200	-	-	3.3	3.8	2.1	2.3	1.5	1.8	1.1	1.2	1.0	1.2
	750	-	-	3.3	3.8	2.4	2.6	1.7	2.0	1.2	1.5	1.1	1.4
	860	-	-	3.3	3.8	2.4	2.6	1.7	2.0	1.3	1.6	1.2	1.4
	1002	-	-	3.3	3.8	2.5	2.7	1.8	2.3	1.3	1.6	1.2	1.4
	1250	-	-	3.3	3.8	2.6	2.8	1.9	2.4	1.4	1.8	1.3	1.5
	1825	-	-	3.6	4.1	2.9	3.1	2.1	2.5	1.6	2.1	1.4	1.7
	2050	-	-	3.6	4.1	3.0	3.2	2.2	2.7	1.7	2.2	1.5	1.8
SPECIFICATION	MHz	TYP	MAX	TYP	MAX	TYP	MAX	TYP	MAX	TYP	MAX	TYP	MAX
Tap Loss IN-TAPn dB	5	13.5	13.8	20.1	20.6	22.5	23.5	24	25	27	28	29.5	30.1
	10	13.0	13.8	19.4	19.9	21	22	24	25	27	28	29.5	30.1
	200	13.5	14.0	19.2	19.7	21.2	22.2	24.2	25.3	27.1	28.2	29.5	30.3
	750	14.8	15.3	19.6	20.1	21.7	22.7	24.7	26.1	27.4	28.7	29.5	30.7
	860	15.1	15.6	19.7	20.2	21.9	22.9	24.8	26.3	27.4	28.8	29.5	30.8
	1002	15.4	15.9	19.8	20.3	22	23	25	26.5	27.5	29	29.5	30.9
	1250	16.0	16.5	20.0	21.5	22.2	23.2	25.2	26.8	27.6	29.2	29.5	31.1
	1825	17.4	18.0	20.7	22.5	22.8	23.8	25.8	27.7	27.9	29.8	29.5	31.5
	2050	18.0	18.8	21.0	23.0	23	24	26	28	28	30	29.5	31.7
SPECIFICATION	MHz			MIN		MIN		MIN		MIN		MIN	
Isolation, OUT-TAPn dB	5-10			24		27		29		34		36	
	10-100			28		28		29		34		36	
	100-750			27		28		29		36		34	
	750-1250			28		28		32		36		32	
	1250-2050			25		28		30		34		32	
SPECIFICATION	MHz	MIN		MIN		MIN		MIN		MIN		MIN	
Isolation, TAP TO TAP, dB	10-50	16		16		16		16		16		16	
	50-100	20		20		20		20		20		20	
	100-750	20		20		20		20		20		20	
	750-1002	20		20		20		20		20		20	
	1002-1250	20		20		20		20		20		20	
	1250-1825	16		16		16		16		16		16	
	1825-2050	12		12		12		12		12		12	

## GigaXtend 4 Port Taps

ATX PART NUMBER		XST-24-08T		XST-24-11		XST-24-14		XST-24-17		XST-24-20		XST-24-23		XST-24-26		XST-24-29	
NOMINAL TAP VALUE, dB		8		11		14		17		20		23		26		29	
SPECIFICATION	MHz	TYP	MAX	TYP	MAX	TYP	MAX	TYP	MAX	TYP	MAX	TYP	MAX	TYP	MAX	TYP	MAX
Insertion Loss IN-OUT dB	5	-	-	4.2	4.6	3.0	3.3	1.8	2.0	1.5	1.6	0.8	0.9	0.6	0.7	0.5	0.6
	10	-	-	4.2	4.6	3.0	3.3	1.8	2.0	1.5	1.6	0.8	0.9	0.6	0.7	0.5	0.6
	200	-	-	4.2	4.6	3.1	3.4	1.9	2.1	1.6	1.7	0.9	1.0	0.7	0.8	0.6	0.7
	750	-	-	4.2	4.6	3.3	3.5	2.1	2.3	1.9	2.0	1.1	1.3	0.8	1.0	0.8	0.9
	860	-	-	4.2	4.6	3.3	3.6	2.1	2.4	1.9	2.1	1.2	1.4	0.9	1.1	0.8	0.9
	1002	-	-	4.2	4.6	3.4	3.6	2.1	2.4	2.0	2.2	1.2	1.4	0.9	1.1	0.9	1.0
	1250	-	-	4.2	4.6	3.5	3.7	2.2	2.5	2.1	2.3	1.3	1.6	1.0	1.2	1.0	1.1
	1825	-	-	4.4	4.8	4.0	4.3	2.4	2.8	2.4	2.7	1.6	1.9	1.1	1.5	1.2	1.3
	2050	-	-	4.6	5.0	4.2	4.5	2.5	2.9	2.5	2.8	1.7	2.0	1.2	1.6	1.3	1.4
SPECIFICATION	MHz	TYP	MAX	TYP	MAX	TYP	MAX	TYP	MAX	TYP	MAX	TYP	MAX	TYP	MAX	TYP	MAX
Tap Loss IN-TAPn dB	5	9.0	9.5	14.0	14.6	16.6	17.4	18.5	19.5	21.5	22.0	24.0	25.0	26.0	27.0	29.0	29.8
	10	9.0	9.8	13.1	13.7	15.4	16.6	18.0	19.0	21.0	21.5	24.0	25.0	26.0	27.0	29.0	29.8
	200	9.1	9.8	12.7	13.5	15.2	16.5	18.1	19.1	21.0	21.6	24.0	25.0	26.0	27.1	29.0	29.8
	750	9.3	9.8	13.2	14.0	15.6	16.5	18.2	19.3	21.0	21.8	24.0	25.0	26.0	27.3	29.0	29.8
	860	9.3	10.0	13.3	14.0	15.7	16.5	18.3	19.3	21.0	21.8	24.0	25.0	26.0	27.3	29.0	29.9
	1002	9.4	10.0	13.5	14.2	15.8	16.5	18.3	19.4	21.0	21.9	24.0	25.0	26.0	27.4	29.0	29.9
	1250	9.5	10.5	13.7	14.5	16.0	16.5	18.4	19.5	21.0	22.0	24.0	25.0	26.0	27.5	29.0	30.0
	1825	11.3	12.0	14.3	15.2	16.9	17.6	18.6	20.9	21.0	22.3	24.0	25.2	26.0	27.9	29.0	30.0
	2050	12.0	13.0	14.5	15.5	17.2	18.0	18.7	21.5	21.0	22.5	24.0	25.3	26.0	28.0	29.0	30.0
SPECIFICATION	MHz			MIN		MIN		MIN		MIN		MIN		MIN		MIN	
Isolation, OUT-TAPn dB	5-10			18.5		22		25		30		32		34		35	
	10-100			25		25		25		30		34		34		35	
	100-750			25		25		26		33		36		38		35	
	750-1250			22		24		28		30		32		34		35	
	1250-2050			21		23		26		30		32		30		36	
SPECIFICATION	MHz	MIN		MIN		MIN		MIN		MIN		MIN		MIN		MIN	
Isolation, TAP TO TAP, dB	10-50	16		16		16		16		16		16		16		16	
	50-100	20		20		20		20		20		20		20		20	
	100-750	20		20		20		20		20		20		20		20	
	750-1002	20		20		20		20		20		20		20		20	
	1002-1250	18		20		20		20		20		20		20		20	
	1250-1825	16		16		16		16		16		16		16		16	
	1825-2050	12		12		12		12		12		12		12		12	

## GigaXtend 2 Port Taps

ATX PART NUMBER		XST-22-05T		XST-22-08		XST-22-11		XST-22-14		XST-22-17		XST-22-20		XST-22-23		XST-22-26		XST-22-29	
NOMINAL TAP VALUE, dB		5		8		11		14		17		20		23		26		29	
SPECIFICATION	MHz	TYP	MAX	TYP	MAX	TYP	MAX	TYP	MAX	TYP	MAX	TYP	MAX	TYP	MAX	TYP	MAX	TYP	MAX
Insertion Loss IN-OUT dB	5	-	-	4.0	4.3	3.0	3.3	2.0	2.3	1.2	1.4	1.0	1.1	0.6	0.7	0.5	0.7	0.5	0.8
	10	-	-	4.0	4.3	3.0	3.3	2.0	2.3	1.2	1.4	1.0	1.1	0.6	0.7	0.5	0.7	0.5	0.8
	200	-	-	4.0	4.3	3.1	3.4	2.0	2.3	1.3	1.4	1.1	1.2	0.7	0.8	0.6	0.8	0.6	0.9
	750	-	-	4.1	4.5	3.2	3.6	2.1	2.5	1.5	1.7	1.2	1.3	0.9	1.1	0.8	0.9	0.8	1.0
	860	-	-	4.1	4.5	3.3	3.6	2.1	2.5	1.6	1.7	1.3	1.4	0.9	1.2	0.8	1.0	0.8	1.1
	1002	-	-	4.1	4.5	3.3	3.6	2.1	2.5	1.6	1.8	1.3	1.4	1.0	1.2	0.9	1.0	0.8	1.1
	1250	-	-	4.1	4.6	3.4	3.7	2.2	2.6	1.7	1.9	1.4	1.5	1.1	1.4	1.0	1.1	0.9	1.2
	1825	-	-	4.2	4.7	3.5	3.9	2.3	2.7	2.0	2.2	1.5	1.7	1.3	1.7	1.2	1.3	1.1	1.3
	2050	-	-	4.2	4.8	3.6	4.0	2.3	2.8	2.1	2.3	1.6	1.8	1.4	1.8	1.3	1.4	1.2	1.4
SPECIFICATION	MHz	TYP	MAX	TYP	MAX	TYP	MAX	TYP	MAX	TYP	MAX	TYP	MAX	TYP	MAX	TYP	MAX	TYP	MAX
Tap Loss IN-TAPn dB	5	4.5	5.1	10.8	11.5	12.4	12.9	15.3	16.0	17.5	18.0	20.5	22.0	23.0	23.8	26.0	27.0	29.5	30.5
	10	4.5	5.0	10.1	10.7	12.1	12.6	15.0	15.7	17.0	17.5	20.0	21.5	23.0	23.8	26.0	27.0	29.5	30.5
	200	4.6	5.0	9.2	10.5	12.1	12.6	15.1	15.6	17.1	17.6	20.1	21.5	23.0	23.8	26.0	27.0	29.5	30.5
	750	4.8	5.4	9.7	10.9	12.3	12.8	15.3	15.8	17.2	18.1	20.2	21.6	23.0	23.8	26.0	27.0	29.5	30.5
	860	4.8	5.5	9.8	11.0	12.3	12.8	15.3	15.8	17.3	18.1	20.3	21.6	23.0	23.8	26.0	27.0	29.5	30.5
	1002	4.9	5.6	10.0	11.2	12.4	12.9	15.4	15.9	17.3	18.2	20.3	21.6	23.0	23.8	26.0	27.0	29.5	30.5
	1250	5.0	6.0	10.2	11.4	12.5	13.0	15.5	16.0	17.4	18.3	20.4	21.6	23.0	23.9	26.0	27.0	29.5	30.5
	1825	6.4	7.4	10.8	12.0	13.2	13.7	15.9	16.7	17.8	18.8	20.6	21.7	23.0	24.1	26.0	27.1	29.9	30.5
	2050	7.5	8.4	11.5	12.4	13.5	14.0	16.0	17.0	18.0	19.0	20.7	21.7	23.0	24.3	26.0	27.2	30.0	30.6
SPECIFICATION	MHz			MIN		MIN		MIN		MIN		MIN		MIN		MIN		MIN	
Isolation, OUT-TAPn dB	5-10			16		19		21		26		29		32		34		38	
	10-100			20		20		22		26		29		32		34		38	
	100-750			21		22		23		27		30		32		35		38	
	750-1250			20		22		23		27		30		30		32		35	
	1250-2050			18		20		22		25		29		28		28		33	
SPECIFICATION	MHz	MIN		MIN		MIN		MIN		MIN		MIN		MIN		MIN		MIN	
Isolation, TAP TO TAP, dB	10-50	16		16		16		16		16		16		16		16		16	
	50-100	20		19		20		20		20		20		20		20		20	
	100-750	19		19		20		20		20		20		20		20		20	
	750-1002	20		19		20		20		20		20		20		20		20	
	1002-1250	20		19		20		20		20		20		20		20		20	
	1250-1825	16		16		16		16		16		16		16		16		16	
	1825-2050	12		12		12		12		12		12		12		12		12	

## GigaXtend All Taps

FREQUENCY	Return Loss All Ports dB, Min	Return Loss, Terminating Taps, All Ports dB, Min	Shielding Effectiveness dB, Min
5-10 MHz	14	15	90
10-100 MHz	16	15	90
100-750 MHz	16	15	90
750-1002 MHz	16	15	90
1002-1250 MHz	16	15	90
1250-1825 MHz	14	14	80
1825-2050 MHz	12	12	80

POWER		
<b>POWER PASSING CONTINUOUS</b>	50-60Hz	15 Amp Max (at any 5/8" port)
	60-90VAC	For models with Drop Power Only: 2 Amp Max (at F port #3, fuse NOT included)
<b>ANALOG HUM MODULATION * (5-2050MHZ)</b>		-60dBc @ 10A
		-55dBc @ 15A
<b>Digital Hum Modulation ** (54-1002MHz)</b>		<1% @ 15A
ENVIRONMENTAL & PHYSICAL		
<b>SHIELDING EFFECTIVENESS</b>	5-1002 MHz	≥ 120dB
	1003 - 1218 MHz	≥ 110dB
	1219 - 2050 MHz	≥ 100dB
<b>WATERPROOF RATING</b>	15 PSI, IP68	
<b>OPERATION TEMPERATURE</b>	-40°C to +60°C	
<b>HUMIDITY</b>	5-95% non-condensing	
<b>EMISSION</b>	FCC 15 subpart B ICES-003 CISPR 32 CISPR 35	
<b>ENVIRONMENTAL</b>	ASTM G 154 – Weathering	
	ASTM B 117 – salt spray	
	ASTM D 3359 – Chip Resist	
<b>DIMENSIONS</b>	141.9mm L * 118.85mm W * 69.6mm H / 5.587" L * 4.679" W * 2.74" H	
<b>WEIGHT</b>	0.54 kg / 1.2lbs	
<b>SURGE RESISTANCE</b>	6kV Combination Wave per IEEE C62.41 Category B3 on all ports	
<b>ELECTRICAL SAFETY</b>	UL62368-1	

\* Analog Hum measured with discrete carriers across band applied with AC current from IN to OUT ports of taps, as per ANSI/SCTE 16 2001R2007

\*\* Digital Hum as measured on Viavi VSE1100 with forward path 6MHz SC-QAM load applied with AC current from IN to OUT ports of taps. FCC mandates <3% digital hum as acceptable. Typical source MER 50dB, MER at OUT or TAP ports at 15A through path current is reduced <0.5dB (i.e no noticeable impact given measurement accuracy of test setup). Will be published with 1.8GHz RF load when gear becomes commercially available for source & test.

## GigaXtend Taps / Signal Conditioners

5-1218 MHz Cable Tilt Equalizers			XSA-CE-1218*									
SPECIFICATION	MHz	-2	-4	-6	-8	-10	-12	-14	-16	-18	-20	-22
<b>Insertion Loss (dB TYP)</b>	5	3.0	5.1	7.1	9.2	11.2	13.2	14.9	17.0	19.0	21.1	23.0
	50	2.7	4.5	6.3	8.1	9.8	11.5	13.0	14.8	16.5	18.3	20.0
	85	2.6	4.3	5.9	7.6	9.2	10.8	12.1	13.8	15.4	17.1	18.6
	102	2.5	4.2	5.7	7.3	8.9	10.4	11.8	13.4	14.9	16.5	18.0
	300	2.1	3.3	4.4	5.5	6.7	7.8	8.7	9.9	11.0	12.1	13.2
	550	1.7	2.5	3.2	4.0	4.7	5.4	6.1	6.8	7.5	8.3	9.0
	870	1.3	1.7	2.1	2.4	2.8	3.1	3.4	3.8	4.1	4.5	4.8
	1002	1.2	1.4	1.6	1.9	2.1	2.3	2.4	2.7	2.9	3.1	3.3
	1218*	1.0	1.0	1.0	1.0	1.0	1.0	1.0	1.0	1.0	1.0	1.0
	+/- dB tol.	0.6	0.6	0.6	1.0	1.0	1.0	1.5	1.5	1.5	1.5	1.5

\*maximum loss spec at 1218MHz is 1.5dB for all 1.2G Cable Equalizers

5-1800 MHz Cable Tilt Equalizers			XSA-CE-1800*								
SPECIFICATION	MHz	-2	-4	-6	-8	-10	-12	-14	-16	-18	-20
Insertion Loss (dB TYP)	5	3.1	5.1	7.2	9.2	11.3	13.4	15.4	17.5	17.5	21.6
	50	2.9	4.7	6.6	8.4	10.3	12.2	14.0	15.9	17.5	19.6
	85	2.8	4.5	6.3	8.0	9.8	11.6	13.3	15.2	17.5	18.7
	102	2.8	4.4	6.2	7.9	9.6	11.4	13.1	14.8	17.5	18.3
	300	2.4	3.8	5.2	6.5	8.0	9.4	10.7	12.2	17.5	14.9
	550	2.1	3.2	4.3	5.3	6.5	7.6	8.7	9.8	17.5	12.0
	870	1.8	2.5	3.4	4.1	4.9	5.7	6.5	7.3	17.5	8.8
	1002	1.7	2.3	3.0	3.6	4.3	5.0	5.7	6.4	17.5	7.7
	1218	1.3	2.2	2.5	2.9	3.5	4.0	4.4	4.9	17.5	4.9
	1800*	0.9	1.7	1.2	1.2	1.3	1.4	1.4	1.5	17.5	1.6
	+ dB tol.	0.6	0.6	0.6	1.0	1.0	1.0	1.5	1.5	1.5	1.5

\*maximum loss spec at 1800MHz is 1.5dB for all 1.8G Cable Equalizers

5-2050 MHz Cable Simulators		XSA-CS-2050*						
SPECIFICATION	MHz	2dB	4dB	6dB	8dB	10dB	12dB	15dB
Insertion Loss (dB TYP)	5	0.1	0.1	0.1	0.1	0.1	0.1	0.1
	50	0.4	0.6	0.6	1	1.3	1.5	2.4
	85	0.5	1	1.1	1.7	2.2	2.6	3.3
	102	0.6	1.1	1.4	2.1	2.8	3.2	3.7
	200	0.9	1.7	2.8	3.9	4.6	5	5.7
	300	1.1	2.1	3.6	4.7	5.3	5.9	7.2
	550	1.5	2.9	4.5	5.8	7.2	8.4	10.1
	870	1.8	4.1	5.8	7.6	9.0	11.1	13.5
	1002	1.9	4.4	6.2	8.1	9.8	12	14.8
	1218	2	4.7	6.8	8.9	10.7	13.3	16.5
	1800	3.2	5.8	8.7	11.4	14.0	17.2	21.4
	2050	3.4	6.4	9.6	12.5	15.2	19.1	23.5
	+ dB tol.*	10%	10%	10%	10%	10%	10%	10%

\* +- dB tol minimum of 0.5dB in all cases

42 MHz Return Path Attenuator, Passband 2050MHz		XSA-RA-42-2050*						
SPECIFICATION	MHz	-03	-06	-09	-12	-15	-18	-21
Insertion Loss (dB MAX)	5	3.0	6.0	9.0	12.0	15.0	18.0	21.0
	42	3.0	6.0	9.0	12.0	15.0	18.0	21.0
	54	2.2	2.8	1.0	1.0	1.0	2.0	2.0
	102	0.5	0.5	0.5	0.5	0.5	0.5	0.5
	300	0.3	0.3	0.3	0.3	0.3	0.3	0.3
	550	0.4	0.4	0.4	0.4	0.4	0.4	0.4
	870	0.7	0.7	0.7	0.7	0.7	0.7	0.7
	1002	0.7	0.7	0.7	0.7	0.7	0.7	0.7
	1218	0.9	0.9	0.9	0.9	0.9	0.9	0.9
	2050	1.4	1.4	1.4	1.4	1.4	1.4	1.4
	+ tol.	10%	10%	10%	10%	10%	10%	10%

85 MHz Return Path Attenuator, Passband 2050MHz		XSA-RA-85-2050*						
SPECIFICATION	MHz	-03	-06	-09	-12	-15	-18	-21
Insertion Loss (dB MAX)	5	3.0	6.0	9.0	12.0	15.0	18.0	21.0
	42	3.0	6.0	9.0	12.0	15.0	18.0	21.0
	85	3.0	6.0	9.0	12.0	15.0	18.0	21.0
	102	0.5	0.5	1.0	1.0	1.0	2.0	2.0
	300	0.3	0.3	0.3	0.3	0.3	0.3	0.3
	550	0.4	0.4	0.4	0.4	0.4	0.4	0.4
	870	0.7	0.7	0.7	0.7	0.7	0.7	0.7
	1002	0.7	0.7	0.7	0.7	0.7	0.7	0.7
	1218	0.9	0.9	0.9	0.9	0.9	0.9	0.9
	2050	1.4	1.4	1.4	1.4	1.4	1.4	1.4
	+/- tol.	10%	10%	10%	10%	10%	10%	10%

## Ordering Information

Part Number	Description
<b>XST-22-*</b>	2 Port Multi-Tap, 5-2050MHz, 15A thru, *= 05T,08,11,14,17,20,23,26,29 dB
<b>XST-24-*</b>	4 Port Multi-Tap, 5-2050MHz, 15A thru, *=08T,11,14,17,20,23,26,29 dB
<b>XST-28-*</b>	8 Port Multi-Tap, 5-2050MHz, 15A thru, *=14T,17,20,23,26,29 dB
<b>XST-22D-*</b>	2 Port Multi-Tap, 5-2050MHz, 15A thru, with Drop Power, *= 08,11,14,17,20,23,26,29 dB
<b>XST-24D-*</b>	4 Port Multi-Tap, 5-2050MHz, 15A thru, with Drop Power, *= 11,14,17,20,23,26,29 dB
<b>XST-28D-*</b>	8 Port Multi-Tap, 5-2050MHz, 15A thru, with Drop Power, *= 17,20,23,26,29 dB
<b>XST-24U-*</b>	4 Port Multi-Tap, 5-2050MHz, 15A thru, w/o Plug-in, *= 08T,11 dB
<b>XST-28U-*</b>	8 Port Multi-Tap, 5-2050MHz, 15A thru, w/o Plug-in, *= 11T,14 dB
<b>XSI-2-20</b>	Power Inserter, 5-2050MHz, 20A
<b>XSC-2-*</b>	Wideband coupler 5-2050MHz, 15A thru, *=04, 08, 12, 16 dB coupler value
	3 way splitters (balanced,unbalanced) *=777, 959
<b>XSA-CE-1800-*</b>	Accessories, 1.8GHz Cable Equalizers, *=02,04,..20 dB
<b>XSA-CE-1218-*</b>	Accessories, 1.2GHz Cable Equalizers, *=02,04,..22 dB
<b>XSA-CS-2050-*</b>	Accessories, 2.05GHz Cable Simulators, *=02,04,06,08,10,12,15 dB
<b>XSA-RA-42-2050-*</b>	Accessories, 42MHz Return Attenuators with 54-2050MHz Passband, *=03,06,..21 dB
<b>XSA-RA-85-2050-*</b>	Accessories, 85MHz Return Attenuators with 102-2050MHz Passband, *=03,06,..21 dB
<b>XSA-FUSE-15A</b>	Accessories, 15A plug-in fuse for GigaXtend (not needed for taps)
<b>XSA-TCG-10</b>	Accessory: cutting guide for KS adapters, 10pc kit
<b>XSA-KSP-10</b>	Accessory: spare watertight plug for 5/8-24 port, 10pc kit
<b>XSA-FUSE-SHUNT-10</b>	Accessory: spare shunt signal director for fuse position (bus bar), 10pc kit
<b>XSA-SHUNT-10</b>	Accessory: spare 0dB RF shunt for plug in position, 10pc kit
<b>XSA-TERMF-100</b>	Accessory: 2GHz 75ohm RF Terminators (F-male), 100pc kit

NOTE: A 'T' suffix on tap part number indicates a Terminating tap that has no OUT port

Products or features contained herein may be covered by one or more U.S. or foreign patents. Other non-ATX product and company names mentioned in this data sheet are the property of their respective companies.



© 2021 by ATX Networks Corp. and its affiliates (collectively "ATX Networks Corp."). All rights reserved. This material may not be published, broadcast, rewritten, or redistributed. Information in this document is subject to change without notice. Rev. 04/2021 (ANW1403)

**ATX Networks**

Tel: 289.204.7800 | Toll Free: 866.YOUR.ATX | support@atx.com